

- 18 Brandabur, M. M. and Mufson, E. J. (1993) *Neurology* 43, A408
- 19 Appel, S. H. (1993) *Trends Neurosci.* 16, 3–5
- 20 Avaraham, K. B. *et al.* (1991) *J. Neurocytol.* 20, 208–215
- 21 Elroy-Stein, O., Bernsetin, Y. and Groner, Y. (1986) *EMBO J.* 5, 615–622
- 22 Hallgren, B. and Sourander, P. (1958) *J. Neurochem.* 3, 41–51
- 23 Gutteridge, J. M. C. (1992) *Clin. Sci.* 82, 315–320
- 24 Jenner, P., Schapira, A. H. V. and Marsden, C. D. (1992) *Neurology* 42, 2241–2250
- 25 Youdim, M. B. H., Ben-Shachar, D. and Riederer, P. (1993) *Movement Disorders* 8, 112
- 26 Dexter, D. T. *et al.* (1990) *J. Neurochem.* 55, 16–20
- 27 Connor, J. R., Menzies, S. L., Snyder, B. S., Loeffler, D. A. and LeWitt, P. A. *J. Neurosci.* (in press)
- 28 Good, P. F., Olanow, C. W. and Perl, D. P. (1992) *Brain Res.* 593, 343–346
- 29 Gutteridge, J. M., Quinlan, G. J., Clark, I. and Halliwell, B. (1985) *Biochim. Biophys. Acta* 835, 441–447
- 30 Sengstock, G. J., Olanow, C. W., Dunn, A. J. and Arendash, G. W. (1992) *Brain Res. Bull.* 28, 645–649
- 31 Ben-Shachar, D. and Youdim, M. B. H. (1991) *J. Neurochem.* 57, 2133–2135
- 32 Sengstock, G. J. *et al.* (1991) *Movement Disorders* 6, 272
- 33 Sengstock, G., Olanow, C. W. and Arendash, G. (1993) *Neurology* 43, A389
- 34 Mizuno, Y. *et al.* (1989) *Biochem. Biophys. Res. Commun.* 163, 1450–1455
- 35 Schapira, A. H. V. *et al.* (1989) *Lancet* i, 1269
- 36 Nicklas, W. J., Vyas, I. and Heikkila, R. E. (1985) *Life Sci.* 36, 2503–2508
- 37 Orrenius, S., Burkitt, M. J., Kass, G. E., Dypbukt, J. M. and Nicotera, P. (1993) *Ann. Neurol.* 32, S33–S42
- 38 Saggu, H. *et al.* (1989) *J. Neurochem.* 53, 692–697
- 39 Marttila, R. J., Lorentaa, H. and Rinne, U. K. (1988) *Neurol. Sci.* 86, 321–331
- 40 Ceballos, I. *et al.* (1990) *Lancet* 335, 1035–1036
- 41 Przedborski, S. *et al.* (1992) *J. Neurosci.* 12, 1658–1667
- 42 Hudson, A. J. (1981) *Brain* 104, 217–247
- 43 Parkinson's Study Group (1993) *N. Engl. J. Med.* 328, 176–183
- 44 Olanow, C. W. and Calne, D. B. (1991) *Neurology* 42, 13–26
- 45 Deng, H. X. *et al.* (1993) *Science* 261, 1047–1051

## debate

Gavin J.  
Swanson  
Editor

The following debate covers a long-standing controversy in neuroscience, namely, whether the cerebellum, which has traditionally been considered to participate only in motor functions, is involved in so-called higher functions, such as cognition and language. Henrietta Leiner, Alan Leiner and Robert Dow consider the evidence in favour of the latter view, by examining the evolutionarily enlarged dentate nucleus in humans.

The first debate in this new section of *TINS* covered another topic of higher cognitive processes, olfactory learning, and resulted in several letters from readers; many of which could not be published as a result of lack of space. Points of interest and comments from readers are always welcome, as are any suggestions for topics of interesting controversy for possible debate in future issues. Please contact the editor.

## Cognitive and language functions of the human cerebellum

Henrietta C. Leiner, Alan L. Leiner and Robert S. Dow

Alan and Henrietta Leiner are at Anning House, 850 Webster Street (635), Palo Alto, CA 94301. Robert S. Dow is at the R. S. Dow Neurological Sciences Institute, Good Samaritan Hospital and Medical Center, 1040 NW 22nd Avenue (L450), Portland, OR 97210, USA.

*Traditionally, the human cerebellum has been regarded as a motor mechanism, but this view of its function is being challenged by a growing body of data on the non-motor functions of the cerebellum. Some of these data are presented in this article, which reviews neuroanatomical, neuroimaging and behavioral reports of cerebellar involvement in cognitive and language functions. The article proposes that this functional expansion is a consequence of specific cerebellar structural changes that evolved during hominid evolution and that could have been a prerequisite for the evolution of human language.*

In research on the neural basis of cognitive and language skills, one of the large structures in the human brain has often been overlooked. This structure is located in the lateral part of the human cerebellum, which enlarged enormously in the course of hominid evolution<sup>1</sup>. Why this part of the cerebellum grew to enormous size in humans has been a long-standing mystery. At first it was assumed that this part conferred a motor benefit on humans; but the motor assumption was thrown into doubt when functional imaging techniques made it possible to visualize cerebellar activity. These images showed that, even in the complete absence of any motor activity, the cerebellum was activated when humans performed certain cognitive and language tasks<sup>2,3</sup>. This cerebellar participation in mental tasks offers an explanation for the cerebellar enlargement: it may have provided the neural basis for a functional expansion of the cerebro-cerebellar system, in which the lateral cerebellum can improve

certain cognitive and language functions<sup>4–6</sup>. How this functional expansion could occur as a consequence of the structural enlargement is discussed in this article.

### The mystery of the human dentate nucleus

In the evolution of the human cerebellum, the most lateral part enlarged both its cortical and subcortical structures<sup>7</sup>. The lateral part of the cerebellar cortex sends its output to a lateral nucleus, called the dentate nucleus in humans, which is embedded in the white matter beneath the cortex (Fig. 1). During the evolution of this nucleus, a significant differentiation occurred, which contrasts with the evolution of the cerebellar cortex. While the newly-evolved part of the cortex is similar histologically to the older parts of the cortex, the newly-evolved part of the dentate nucleus is different from the older part of the nucleus. This differentiation between the newly-evolved part (ventrolateral) and the older part (dorsomedial) is based on morphological, histological, embryological, histochemical, and pathological evidence<sup>7</sup>.

Because this neodentate part of the cerebellum grew to enormous size in humans, an obvious question has arisen about its function in the human brain. Neurosurgeons have provided a provocative piece of evidence by reporting that stereotaxic lesions, when placed in the neodentate, fail to produce some classical motor signs of cerebellar

dysfunction (ataxia or tremors)<sup>8</sup>. Such reports lead us to ask whether the neodentate might be performing a non-motor function<sup>9</sup>.

Clues to its function are provided by the output connections through which the neodentate can send signals to other structures in the human brain. These target structures of the cerebellar signals are located in widely separated locations: in the brainstem, in the thalamus and (via the thalamus) in the cerebral cortex. Though dispersed in the brain, these structures are able to send signals to each other via the neural connections that evolved between them, which enable them to communicate with each other as parts of a coherent system (Fig. 2). The expanded connections from the cerebellum to the cerebral cortex, and from the cerebral cortex to the cerebellum, seem to provide this system with expanded cognitive and language capabilities<sup>9,10</sup>.

#### Expanded connections to the cerebral cortex

It has been difficult to investigate the neural connections that evolved between the neodentate and the cerebral cortex because the usual experimental animals cannot be used for this purpose. In the monkey, the neodentate is not yet fully differentiated; and in the apes it is not yet fully enlarged. The data that are available about these neodentate connections have therefore come from human patients whose brains were examined during their lifetimes by neurosurgeons, neurologists and neuroradiologists, or were examined post-mortem by neuropathologists. The picture that emerges from such examinations is at least consistent; it shows that in humans the primary target of the neodentate projection is the frontal lobe. This lobe is known to have enlarged in the course of hominid evolution, both in its posterior areas (motor areas) and in its anterior areas (prefrontal association areas), concomitantly with cerebellar enlargement<sup>1</sup>.

Although it is generally recognized that the projection from the cerebellum reaches the motor areas of the frontal lobe (areas 4 and 6 of Brodmann), it is not widely recognized as yet that the cerebellar projection also reaches some prefrontal areas of the lobe. These particular prefrontal areas lie directly in front of the motor areas, which suggests that the enlargement of the frontal lobe made it possible for the cerebellar projection to expand into these forward territories. While the exact extent of this forward expansion is not yet known, there is evidence that (at the least) it reaches Broca's language area in the inferior prefrontal

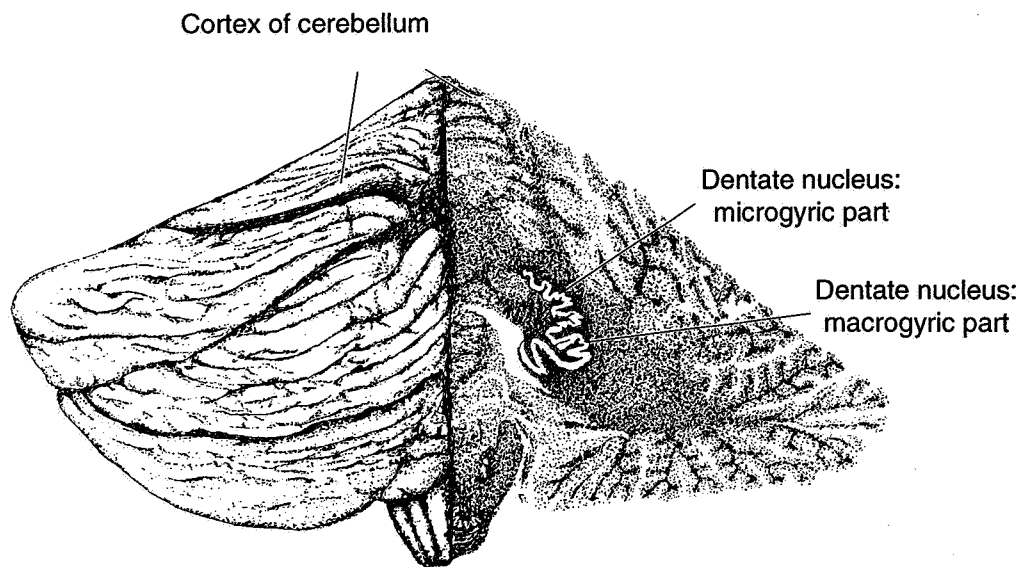

**Fig. 1.** Newly-evolved structures in the human cerebellum, cortical and subcortical. On the left side of the figure, a surface view of the cerebellar cortex is shown; its most lateral part enlarged enormously in the course of hominid evolution, as did the subcortical dentate nucleus. On the right side of the figure, a cross-section (coronal slice) of the cerebellum reveals its inner core, where the dentate nucleus can be seen. Note the gross differences between the two parts of the dentate nucleus: the part that is phylogenetically new is located ventrolaterally and is characterized by wide gyri (macrogyric) while the phylogenetically older part is located dorsomedially and is characterized by narrow gyri (microgyric). The phylogenetically new part (the neodentate) enlarged enormously in the human brain. Its function remains undetermined, but we have proposed that it may be involved in some mental functions including language. [Figure adapted from Angevine, J. B., Mancall, E. L. and Yakovlev, P. I. (1961) *The Human Cerebellum, An Atlas of Gross Topography in Serial Sections*, Little, Brown and Co.]

cortex (areas 44 and 45 of Brodmann), and area 8 in the superior prefrontal cortex. The neuroanatomical routes by which the cerebellum can send signals to these prefrontal areas are specified in our previous publications, to which the reader is referred for details<sup>5,9,10</sup>.

What is interesting about these particular prefrontal areas is that their functions were initially thought to be motor ones, related to speech and eye movements, but now seem to be broader. This expanded view of their functions is based on imaging studies<sup>11</sup> and on neurosurgical reports<sup>12</sup>. Area 8, which was initially regarded as a motor area because it is involved in eye movements, seems to be activated (even with the eyes closed) when humans listen to verbal information<sup>11</sup>; and when surgical excisions of this area are performed, deficits in mentation are reported to ensue<sup>12</sup>. Broca's area also was initially thought to subservise a motor function because it is activated when humans express themselves verbally; but it is activated as well when no words are uttered<sup>11</sup>. Rather than subserving the motor function of word-articulation (which involves the motor cortex of the frontal lobe), Broca's prefrontal area and adjacent prefrontal areas seem to be involved in processes of word-finding<sup>13</sup>, which are regarded as cognitive processes. In such cognitive word-processing, the lateral cerebellum evidently participates<sup>2</sup>.

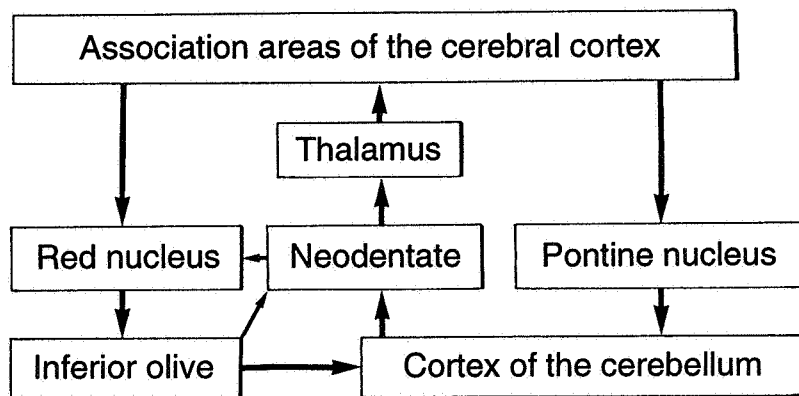

**Fig. 2.** Newly-evolved connections between the cerebellum and cerebral cortex. Neural connections from the neodentate (via the thalamus) can reach cerebral association areas, including Broca's language area in the prefrontal cortex. Conversely, neural connections from cerebral association areas can reach the cerebellum, both via the pontine route and via the route from the red nucleus to the inferior olive. Note that the cortex of the cerebellum therefore receives a dual input of neural fibers: it receives mossy fibers from the pontine nuclei and climbing fibers from the inferior olive. Such a dual input of mossy fibers and climbing fibers is a basic characteristic of cerebellar input – characteristic of every module in the entire cerebellar cortex. The functional significance of the climbing fibers is still under debate. Also under debate is the function of the neural loop in the brainstem (formed by the connections from the inferior olive to the dentate nucleus to the red nucleus to the inferior olive), which we have proposed may be involved in language learning.

**Expanded connections from the cerebral cortex**

From Broca's area in the prefrontal cortex, as well as from other areas of the cerebral cortex, a descending projection of nerve fibers can reach the red nucleus in the brainstem<sup>14</sup>, where an interesting

evolution of structure and function has taken place. In most mammals the red nucleus sends its major output to the spinal cord and it clearly subserves a motor function. But this projection to the spinal cord has diminished in the human brain<sup>15</sup> where the red nucleus sends its major output to the inferior olive in the brainstem. In turn, the inferior olive is connected to the dentate nucleus, which is connected to the red nucleus (Fig. 2). Thus, in the human brainstem a neural loop has evolved in which the red nucleus receives a projection from language areas of the cerebral cortex. This input to the red nucleus would enable the neural loop to participate in language functions as well as motor functions. It could participate both in the cognitive process of word-finding and in the motor process of expressing these words, perhaps functioning as a language-learning loop<sup>6,9,10</sup>.

Far more massive than the projection from the cerebral cortex to the red nucleus is the cortical projection to the pontine nuclei in the brainstem, which also send information to the cerebellum (Fig. 2). Estimated to contain approximately 20 million nerve fibers on each side of the brain<sup>16</sup>, this neural tract can convey a formidable amount of information. To appreciate fully its formidable power, the reader is invited to compare this tract with other effective tracts in the brain. Consider how much information the optic tract, with its one million fibers, can convey from the eyes to the brain; or consider how much information the pyramidal tract, with its one million fibers, can convey from the brain to the motor neurons. Such comparisons inevitably lead one to wonder why the cortex of the cerebellum receives this torrent of information from many lobes of the cerebral cortex, via the pons.

What motor functions this information can subserve<sup>17</sup>, and what non-motor functions it might subserve<sup>18-20</sup>, are discussed in recent reviews. In the present review, we have concentrated only on the phylogenetically newest parts of the cerebro-cerebellar system, and have reached the following conclusions.

**Expanded cerebro-cerebellar capabilities**

We contend that, in the brains of all vertebrates, the cerebellum can improve the performance of any other parts of the brain to which it is reciprocally connected. Because the cerebellar connections to other parts of the brain are different in different species, the specific functions that the cerebellum can improve also differ. For example: when the cerebellum is connected to sensory parts of the brain (as it is conspicuously in an electric fish<sup>20</sup>), the cerebellum

**TABLE I.** Cerebellar participation in human mental functions

Subjects	Published data	Refs
Normal adults, SPECT scans	Cerebellar activation during mental imagery	3
Normal adults, PET scans	Cerebellar activation during word-processing	2
Children whose cerebellum is normal but cerebrum is reduced	Good linguistic skills	31
Children with cerebellar damage due to surgical resection	Cognitive deficit in shifting attention rapidly between sensory modalities	29
Adult patient with cerebellar degeneration	Deficits in verbal and non-verbal intelligence, in verbal associative learning, and in visuospatial skills	29
Adult patient with a right-side cerebellar infarct	Impaired non-motor learning and error-detection	2
Patients with bilateral or unilateral cerebellar damage	Deficits in visuospatial organization, in cognitive planning and in speed of information-processing	24
Patients with cerebellar atrophy	Deficits in cognitive planning	26
	Deficits in word-retrieval	27
	Deficits in procedural learning	28
Patients with cerebellar lesions or atrophy	Deficits in verbal associative learning, in spatial and general intelligence	25
Patients with cerebellar lesions	Impaired in judging time intervals and in judging velocity of moving stimuli	19
Patients with lesions in the left neocerebellum	Deficits in cognitive operations in three-dimensional space	30

In this Table only the most recent references are given; in them can be found previous references that are pertinent to this topic. Abbreviations: PET, positron emission tomography; SPECT, single photon emission computed tomography.

can modulate sensory functions; when it is connected to limbic parts of the brain (as it is in mammals), the cerebellum can modulate emotional and vegetative functions<sup>4</sup>; when it is connected to some cognitive parts of the frontal cortex (as it is in humans), the cerebellum also can improve cognitive processes that are associated with human language. Exactly what operations the cerebellum carries out, in improving such functions, is still a matter of debate<sup>17-23</sup>. However, we have shown that the newly-evolved structures of the cerebellum can send signals via ascending connections to cerebral association areas and conversely that cerebral association areas can send signals via descending connections to the newly-evolved structures of the cerebellum (Fig. 2). Such two-way communications make it possible for these cerebro-cerebellar structures to work together in carrying out specific cognitive and language tasks.

Data on cerebellar participation in cognitive and language functions (Table I) have been produced in recent years both by the neuroimaging of normal adult brains<sup>2,3,11</sup> and by the neuropsychological testing of patients in whom the cerebellum is defective<sup>19,24-30</sup>. Also, a group of retarded children was tested in whom the volume of cerebral cortex is reduced but the cerebellum is normal. Despite their retardation these children exhibit remarkable linguistic competence<sup>31</sup>.

Specific data on the participation of the lateral cerebellum in language functions (as distinct from speech) were obtained from normal adults whose brains were imaged by positron emission tomography (PET) scans<sup>2</sup>. These adults, who had no prior practice in the tasks assigned to them, were required to generate a cognitive association between words. A noun was presented to them and they had to think of a verb associated with the use of the noun (e.g. 'needle' associated with 'sew'). The neuroimaging revealed a striking activation in the inferior lateral part of the cerebellum, which was anatomically distinct from the activation in the paramedian part of the cerebellum during motor tasks, including speech<sup>2</sup>.

Data on cerebellar participation in cognitive processing also were obtained from a different group of normal adults who were required to count silently and to imagine certain sequences of movements. This mental imagery was not accompanied by any sensory stimulation or any motor activity, and therefore was deemed to be purely cognitive. The inferior lateral part of the cerebellum was activated markedly during both the mental counting and the mental imagery<sup>3</sup>.

In addition to these data on adults and children with normal cerebella, data have been obtained from patients with defective cerebella, who exhibit deficits in several cognitive domains. These include, for example, deficits in cognitive planning<sup>24,26-28</sup>, in practice-related learning and error-detection<sup>2</sup>, in learning arbitrary associations between words<sup>25</sup>, in judging time intervals and the velocity of moving stimuli<sup>19</sup>, in rapidly shifting attention between sensory modalities<sup>29</sup>, and in cognitive operations in

three-dimensional space<sup>30</sup>. See Table I for specific details.

In the light of these neuroanatomical, neuroimaging and behavioral data, the traditional view of the cerebellum as serving a purely motor function seems to be unduly narrow. So too do the proposed theoretical models of cerebellar function seem unduly narrow when their explanations are limited to the motor system. Fortunately, one of the models that was proposed to explain motor functions has now been expanded to include mental functions as well<sup>21</sup>. In the future, theoreticians may be able to expand other proposed models also, so that they reflect more adequately the actual scope of cerebro-cerebellar capabilities in the human brain. Such models could help to ensure that the connections of the neodentate will not be overlooked in future research on the neural basis of human cognitive and language functions.

#### Selected references

- 1 Passingham, R. E. (1975) *Brain Behav. Evol.* 11, 73-90
- 2 Peterson, S. E. and Fiez, J. A. (1993) *Annu. Rev. Neurosci.* 16, 509-530
- 3 Ryding, E., Decety, J., Sjöholm, H., Stenberg, G. and Ingvar, D. H. (1993) *Cogn. Brain Res.* 1, 94-99
- 4 Dow, R. S., Kramer, R. E. and Robertson, L. T. (1991) in *Clinical Neurology (Vol. 3)* (Joynt, R. J., ed.), pp. 97-143, Lippincott
- 5 Leiner, H. C., Leiner, A. L. and Dow, R. S. (1986) *Behav. Neurosci.* 100, 443-454
- 6 Leiner, H. C., Leiner, A. L. and Dow, R. S. (1987) *Ital. J. Neurol. Sci.* 8, 425-436
- 7 Dow, R. S. (1942) *Biol. Rev. Camb. Philos. Soc.* 17, 179-220
- 8 Siegfried, J., Esslen, E., Gretener, U., Ketz, E. and Perret, E. (1970) *Confin. Neurol.* 32, 1-10
- 9 Leiner, H. C., Leiner, A. L. and Dow, R. S. (1989) *Behav. Neurosci.* 103, 998-1008
- 10 Leiner, H. C., Leiner, A. L. and Dow, R. S. (1991) *Behav. Brain Res.* 44, 113-128
- 11 Roland, P. E. (1984) *Trends Neurosci.* 7, 430-435
- 12 Penfield, W. (1948) *J. Nerv. Ment. Dis.* 27, 519-534
- 13 Tonkonogy, J. and Goodglass, H. (1981) *Arch. Neurol.* 38, 486-490
- 14 Archambault, L. (1914) *Nouvelle Iconographie de la Salpêtrière* 27, 188-225
- 15 Nathan, P. W. and Smith, M. C. (1982) *Brain* 105, 223-269
- 16 Tomasch, J. (1969) *Brain Res.* 13, 476-484
- 17 Stein, J. F. and Glickstein, M. (1992) *Physiol. Rev.* 72, 967-1017
- 18 Schmahmann, J. D. (1991) *Arch. Neurol.* 48, 1178-1187
- 19 Ivry, R. B. and Baldo, J. U. (1992) *Curr. Opin. Neurobiol.* 2, 212-216
- 20 Paulin, M. G. (1993) *Brain Behav. Evol.* 41, 39-50
- 21 Ito, M. (1990) *Rev. Neurol.* 146, 564-569
- 22 Bloedel, J. R. (1992) *Behav. Brain Sci.* 15, 666-678
- 23 Thach, W. T., Goodkin, H. P. and Keating, J. G. (1992) *Annu. Rev. Neurosci.* 15, 403-442
- 24 Botez, M. I. (1992) *Arch. Neurol.* 49, 1229-1230
- 25 Bracke-Tolkmitt, R. et al. (1989) *Behav. Neurosci.* 103, 442-446
- 26 Grafman, J. et al. (1992) *Neurology* 42, 1493-1496
- 27 Appollonio, I. M., Grafman, J., Schwartz, V., Massaquoi, S. and Hallett, M. (1993) *Neurology* 43, 1536-1544
- 28 Pascual-Leone, A. et al. *Ann. Neurol.* (in press)
- 29 Akshoomoff, N. A. and Courchesne, E. (1992) *Behav. Neurosci.* 106, 731-738
- 30 Wallesch, C. W. and Horn, A. (1990) *Brain Cogn.* 14, 19-25
- 31 Bellugi, U., Wang, P. P. and Jernigan, T. L. in *Atypical Cognitive Deficits in Developmental Disorders: Implications for Brain Function* (Broman, S. and Grafman, J., eds), Lawrence Erlbaum (in press)

## Movement and thought: identical control mechanisms by the cerebellum

Commentary by  
Masao Ito  
Frontier Research  
Program, RIKEN,  
Wako, Saitama  
351-01, Japan.

During the past three decades, knowledge of the cerebellum has increased markedly, and research has yielded important new concepts such as micro-zones of the cerebellar cortex, synaptic plasticity and motor learning. Furthermore, involvement of the cerebellum in a certain category of mental functions has become apparent based on the anatomical and pathophysiological findings proposed in the keynote article by Leiner, Leiner and Dow in this issue. I support this proposal from the viewpoint of control systems: the cerebellum acquires 'dynamics' or 'inverse dynamics' of a control object through repeated exercise, and using 'dynamics memory' it automates quick, precise and smooth control of a learned movement. This control system principle applies primarily to movement, but it is general enough to apply to any type of neural control including that of mental functions, such as thought. Here, I trace the development of control system theories of the cerebellum up to mental control problems.

The fundamental functional module of the cerebellum is the corticonuclear microcomplex (CNMC), consisting of a small area of the cerebellar cortex (microzone), a small group of vestibular or cerebellar nuclear neurons and a small group of inferior olive neurons<sup>1</sup>. These structures are interconnected in such a way that the major signal flow from a mossy fiber pathway (*m* in Fig. 1A) to the nuclear group is modulated by its sidepath signal flow through the microzone, and that this modulation is modified according to error signals (*c* in Fig. 1A) mediated by the inferior olive neurons. As a basis for this error-driven adaptation in CNMCs, long-term depression (LTD) occurs in the synapses on a Purkinje cell, which are active at the time when error signals arrive<sup>2</sup>. An argument has been raised as to whether or not additional synaptic plasticity of nuclear neurons accounts for memory storage within the CNMC<sup>3,4</sup>. However, this argument does not affect the basic idea that the CNMC is the functional module of the cerebellum, and that LTD plays an essential role in its learning mechanism.

The most fundamental form of neural control system is a reflex, which can be either autonomic or motor. The vestibulo-ocular reflex (VOR) generates eye movements that compensate for head movements, so as to minimize retinal errors during movement. The VOR is adaptively modified when retinal errors are artificially amplified by means of prism or lens goggles or rotation of visual surrounds in various combinations with head rotation. This adaptability is abolished by lesions of the cerebellar flocculus. In our model<sup>5</sup>, the CNMC, including the flocculus, vestibular organs and vestibular nuclear neurons relaying the VOR, constitutes a controller acting upon the control object which includes the brainstem oculomotor system, eye muscles and eye ball (Fig. 1B). Here, the CNMC is viewed as an adaptively modifiable controller. Its performance is

perfect when the output of the VOR, eye velocity, is equal to the input, head velocity, with the sign reversed: this is achieved when the CNMC attains a dynamics ( $1/g$ ) inversely equal to that of the control object ( $g$ ).

A control system model has also been developed for voluntary movement, such as touching one's nose with one's finger. The fact that a normal subject can bring his finger quickly and accurately to his nose with his eyes closed, i.e. without feedback (finger-to-nose test), suggests a learning process that converts the finger control from a feedback mode to a feedforward mode. Since patients with cerebellar injury fail the finger-to-nose test, the learning process appears to be situated in the cerebellum. Based on the loop connection between the paravermal part of the cerebellum and the cerebral motor cortex, it is thought that while the motor cortex (CX in Fig. 1C) receiving instruction for a finger movement acts as a controller of the finger skeletomuscular system by referring to visual feedback (*eff*), the CNMC including the paravermal cortex develops, through practice, dynamics ( $g'$ ) equivalent to the  $g$  of the skeletomuscular system<sup>1</sup>. Thence, it is possible that the motor cortex acts through the dynamics model instead of the actual skeletomuscular system, and that the external feedback loop is replaced by an internal loop through the cerebellum.

However, other areas of the cerebral and cerebellar cortices are connected in a parallel fashion instead of a loop fashion<sup>1</sup>. The third step of modeling thus involves the assumption that the cerebellum is a feedforward controller acting in parallel with a feedback controller, the cerebral cortex, on the same control object<sup>6</sup> (Fig. 1D). When the feedforward control system reproduces, through practice, an arm trajectory equivalent to the instructed trajectory, the controller should bear a dynamics ( $1/g$ ) inversely equal to the dynamics of the skeletomuscular system of the limb ( $g$ ). When the instructed trajectory to the nose is fed into the inverse dynamics model in the cerebellum, the finger forms a trajectory identical to the given instruction. It is interesting to note that the basic role of the CNMC here is the same as in the most primitive form of cerebellar control of a reflex, shown in Fig. 1B.

It is important to note that what is learnt in these models is the dynamics or inverse dynamics, not the individual trajectory actually practiced. The simulation study of Kawato *et al.*<sup>6</sup> demonstrated that after practice of a particular trajectory with a combination of the two models of Fig. 1C and D, a robot will form trajectories in any directions accurately and smoothly. I propose the term 'dynamics learning' for expressing this manner of learning. The cerebellar circuitry retains 'dynamics memory' (either inverse or not) but not memory of

individual trajectories. The failure of the finger-to-nose test in patients with cerebellar injury thus represents loss of 'dynamics memory' of the arm. Theoretical bases for the dynamics and inverse dynamics model formation in the cerebellum have been thoroughly explored by Kawato and Gomi<sup>7</sup>.

It is also important to note that in the above control schemes, the cerebral cortex is assisted by two cerebellar models in different manners. A dynamics model built into the paravermis-interpositus division of the cerebellum enables the motor cortex to direct limb movement without peripheral feedback. Thus, during repeated exercise, one becomes able to move quickly, precisely and smoothly without referring to sensory feedback. By contrast, an inverse dynamics model built into the hemisphere-dentatus division of the cerebellum replaces the controller task of the motor cortex, rendering the control more automatic and less conscious. Hence, after repeated exercise, one becomes able to move quickly, precisely and smoothly even without conscious thought. The idea of the two models matches the previous notion that the paravermis-interpositus division updates programmed movements throughout their course of execution, while the hemisphere-dentatus division is involved in the programming of movement parameters before movement initiation<sup>8-10</sup>.

Finally, it is pointed out that the control schemes in Figs 1C,D are so general that they may well apply to control cases other than movement. For example, CX may represent an area in the prefrontal cortex acting as a controller of another area in the parieto-temporal cortex which subserves a control object, while the lateral-most part of the human cerebellum provides models for the control object area. This view may be justified in view of the common features of movement and thought as control objects. In thought, ideas and concepts are manipulated just as limbs are in movement. There would be no distinction between movement and thought once encoded in the neuronal circuitry of the brain; therefore, both movement and thought can be controlled with the same neural mechanisms<sup>5,11</sup>. One may recall that thought becomes more automatic and less conscious after repeated exercise, just as movement does. It has recently been shown that in simple forms of thought such as arithmetical counting or route-finding, local blood circulation increases in the prefrontal and parieto-temporal association cortices<sup>12</sup>. It has also been shown that local blood circulation is enhanced in the cerebellar hemisphere during arithmetical counting<sup>13</sup> and certain language tests<sup>14</sup>. An obvious question that follows is what is the dynamics or inverse dynamics model of an idea or a concept? To answer this question, it is necessary to know their representation in the brain, which is as yet unclear. At this stage of investigation, I would simply refer to the mental model of Johnson-Laird<sup>15</sup>.

Massive projection from the cerebral cortex to the inferior olive via the parvocellular red nucleus in humans is emphasized in the keynote article by Leiner, Leiner and Dow. In the above models, this

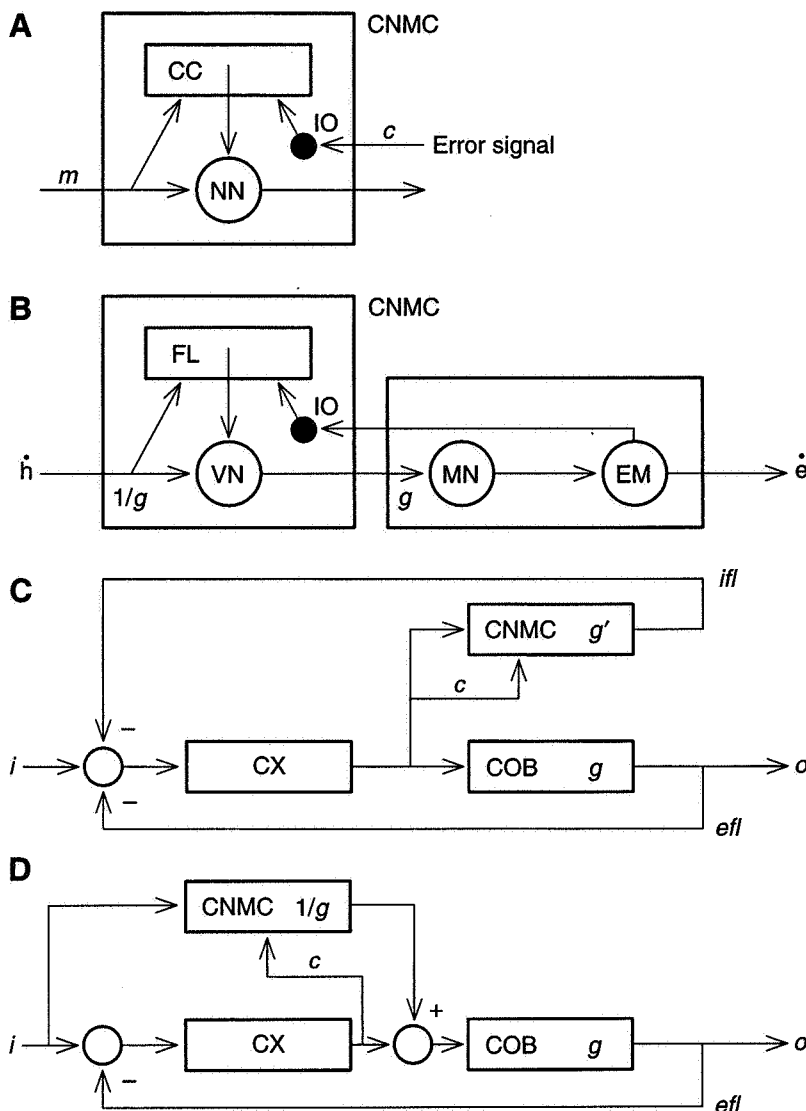

Fig. 1. Models postulated for the control system theories of the cerebellum. Details of each are given in the text. Abbreviations: *c*, climbing-fiber pathway; *CC*, cerebellar cortex; *CNMC*, corticonuclear microcomplex; *COB*, controlled object; *CX*, motor cortex;  $\dot{e}$ , eye velocity; *efl*, external feedback loop; *EM*, eye muscles; *FL*, cerebellar flocculus; *g, g'*, motor dynamics;  $\dot{h}$ , head velocity; *i*, input; *iff*, internal feedback loop; *io*, inferior olive; *m*, mossy-fiber pathway; *o*, output.

projection should convey error signals to the CNMC. Error might be detected in various ways in principle, but, as assumed by Kawato and Gomi<sup>7</sup>, it could be derived from the cerebral cortex which amplifies error detected by comparison of instruction with feedback signals (Fig. 1D). Another massive projection from the cerebral cortex to the cerebellum through pontine nuclei should convey command into the dynamics model (Fig. 1C) or instruction to the inverse dynamics model (Fig. 1D).

Eventually, the models of Fig. 1C and D will be able to be extended to any kind of neural control which our CNS may exert upon a great variety of structures in the body, including the brain. The cerebellum may be viewed in this way as a multipurpose learning machine which assists all kinds of neural control, autonomic, motor or mental (verbal or nonverbal).

**Selected references**

- 1 Ito, M. (1984) *The Cerebellum and Neural Control*, Raven Press
- 2 Ito, M. (1989) *Annu. Rev. Neurosci.* 12, 85–102
- 3 Lisberger, S. G. and Sejnowsky, T. J. (1992) *Nature* 360, 159–161
- 4 Ito, M. (1993) *Nature* 363, 24–25
- 5 Ito, M. (1990) *Rev. Neurol.* 146, 564–569
- 6 Kawato, M., Furukawa, K. and Suzuki, R. (1987) *Biol. Cybern.* 57, 169–185
- 7 Kawato, M. and Gomi, H. (1992) *Trends Neurosci.* 15, 445–453
- 8 Eccles, J. C. (1969) in *Information Processing in the Nervous System* (Leibovic, K. N., ed.), pp. 245–269, Springer-Verlag
- 9 Evars, E. V. and Thach, W. T. (1969) *Annu. Rev. Physiol.* 31, 451–498
- 10 Allen, G. I. and Tsukahara, N. (1974) *Physiol. Rev.* 54, 957–1006
- 11 Ito, M. (1993) in *Brain Mechanisms of Perception and Memory* (Ono, T., Squire, L. R., Raichle, M. B., Perret, D. A. and Fukuda, M., eds), pp. 651–658, Oxford University Press
- 12 Roland, P. E. and Friberg, L. (1985) *J. Neurophysiol.* 53, 1219–1243
- 13 Decety, J., Sjöholm, H., Ryding, E., Stenberg, G. and Ingvar, D. H. (1990) *Brain Res.* 535, 313–317
- 14 Peterson, S. E., Fox, P. T., Posner, M. I., Mintum, M. and Raichle, M. E. (1990) *J. Cognitive Neurosci.* 1, 153–170
- 15 Johnson-Laird, P. N. (1983) *Mental Model*, Cambridge University Press

## **Motor skills but not cognitive tasks**

**Commentary by**  
**M. Glickstein**  
Dept of Anatomy,  
University College  
London, Gower  
Street, London,  
UK WC1E 6BT.

Drs Leiner, Leiner and Dow propose that the cerebellum is intimately involved with complex mental functions such as cognition and language. In the past, the Leiners<sup>1–3</sup> and others have argued along similar lines for these and other non-motor functions of the cerebellum. For example; Schmahmann included affective and emotional control by the cerebellum along with cognition<sup>4</sup>. In support of these ideas, the authors point out that the cerebellum receives a major input from association areas of the cerebral cortex, and that its output projects to a much wider territory in the cerebral cortex than just the motor cortex. For example, they suggest that an efferent connection to Broca's area by way of the ventral thalamus might serve as the anatomical basis for cerebellum's proposed role in language functions. On the afferent side, they point out that the cerebellar hemispheres have a major input from association areas of the cerebral cortex; hence, they can play a role in cognition.

The cerebellum is indeed both absolutely and relatively a large subdivision of the human brain. In fact, an even stronger case than is made in the present paper for the great expansion of the human cerebellar hemispheres and their output via the dentate nucleus was made by Matano and his colleagues<sup>5</sup>. However, size alone is not a sufficient argument to demonstrate cognitive or affective functions. Because of their sizes the basal ganglia and the corpus callosum have also been implicated in such functions in the past.

The classical descriptions of Holmes<sup>6</sup> and others emphasized motor deficits but no mention was made of cognitive or mental dysfunction in their cerebellar patients. The direct evidence for such dysfunctions in patients with traumatic lesions of the cerebellum is minimal. Those instances in which there are non-motor symptoms in degenerative diseases which involve the cerebellum, may well be accounted for by additional damage to other brain structures.

Although the cerebellum is indeed very large in humans, the anatomical evidence for proposed cerebellar functions in cognition and language, is not completely convincing. The input to the cerebellum from association areas of the cerebral cortex is from areas which are particularly involved

in the sensory guidance of movement, not in cognition. The great majority of the cerebellar output is to brain structures which control movement.

The authors suggest that a possible pathway from the dentate nucleus to Broca's area may be the anatomical basis for a role for the cerebellum in language functions. Since efferent fibres from the dentate nucleus cross the midline, Broca's area would receive its input mainly from the right side of the cerebellum. If the cerebellum were absolutely necessary for speech, then loss of the right cerebellar hemisphere or dentate nucleus should produce profound impairment. A recent case of Fiez *et al.* shows this not to be true<sup>7</sup>. A 49-year-old lawyer suffered a vascular lesion of the cerebellum. The PET scan of this patient shows a massive infarct of the right cerebellar hemisphere. On standard tests of memory, intelligence and language function his performance was excellent, and he soon went back to his law practice. He did have a deficit in practice-related learning and detection of errors, which as Fiez *et al.* emphasized are not primarily motor in character. However, had the stroke been in a region of cerebellum which provides an essential input to Broca's area his language functions would have been impaired. It is unlikely that he would have been able to resume his legal practice quite so promptly.

There is little anatomical evidence for a large projection from the dentate nucleus to non-motor areas of the frontal lobes as the paper suggests. A projection to cortical area 8, the frontal eye fields in monkeys, is known but the evidence from activity-scanning is consistent with this region being primarily an oculomotor area in humans.

In support of a proposed role for the cerebellum in cognition, the authors point out that it receives an input from the association cortex by way of the pontine nuclei. The use of the term association cortex in this context may be misleading. The cerebellum does have an input from regions traditionally described as association cortex, but the functions of those areas are now better known than they were when the term was first coined. There are now more than 30 independent visual areas which have been described in the monkey in the regions

bordering the primary visual cortex<sup>8</sup>, traditionally known as visual association cortex. These visual areas are interconnected in complex ways and their cells have receptive fields which vary greatly. On the basis of response properties and anatomical connections, the extrastriate visual areas have been subdivided into two major streams, both originating in the striate cortex. One, a lateral group, has as its ultimate target the visual areas of the inferotemporal cortex. The other, a medial group, has as its final target the visual areas of the parietal lobe. The lateral stream, which is directed at the temporal lobes, contains neurons whose receptive fields are particularly concerned with the analysis of form and colour. Consistent with these visual properties, lesions of the inferotemporal cortex produce deficits in visual discrimination learning without impairing the visual control of movement. The medial, parietal lobe visual areas contain neurons that are especially sensitive to visual motion. Lesions of the parietal lobe visual areas produce profound deficits in visually guided movement, but not in visual recognition<sup>9</sup>. There is a major projection to the cerebellum by way of the pontine nuclei from cells in the medial, parietal lobe visual stream, whilst the ventrolateral temporal visual areas send sparse or no inputs to the pontine nuclei<sup>10</sup>.

Motion-sensitive cells in the parietal lobe provide the necessary input to the cerebellum for the visual guidance of movement. The cerebellum's visual input is from those cortical areas whose neurons are sensitive to motion, not form. If the cerebellum were involved in cognitive processes it should have at least an equal input from temporal lobe areas that are essential for coding and learning about the nature of objects; their colours and their shapes.

Although the evidence is insufficient to accept a role for the cerebellum in cognition, the problem of why it should be so large remains. The cerebellar hemispheres have more cells than the cerebral cortex. What on earth do they do? One possibility

to account for the remarkable size of these structures is their role in motor learning. Miall *et al.*<sup>11</sup> and others have suggested that the cerebellum's fundamental role is one of predictive control. The cerebellum may contain neural models of the body's muscles and joints whose movements are to be controlled. So, when a motor command is given it is programmed with the help of these models. By predicting the nature of a movement the cerebellar models can be used to optimize it. Hence, the cerebellum is essential for learning motor skills but not for purely cognitive tasks.

To summarize, based on the anatomical evidence, the suggestion that the cerebellum is involved in cognitive and mental functions must be questioned. Patients can have essentially normal language after cerebellar lesions, although their articulation may be impaired. The cerebellum receives a visual input from those areas of the cerebral cortex that are involved in the coding of movement. The extrastriate visual areas which project to the cerebellum are particularly appropriate for providing the visual input to the cerebellum for guiding movements.

#### Selected references

- 1 Leiner, H., Leiner, A. and Dow, R. (1986) *Behav. Neurosci.* 100, 443–454
- 2 Leiner, H., Leiner, A. and Dow, R. (1989) *Behav. Neurosci.* 103, 998–1008
- 3 Leiner, H. C., Leiner, A. L. and Dow, R. S. (1991) *Behav. Brain Res.* 44, 113–128
- 4 Schmahmann, J. (1991) *Arch. Neurol.* 48, 1178–1187
- 5 Matano, S., Baron, G., Stephan, H. and Frahm, H. (1985) *Folia Primatol.* 44, 182–203
- 6 Holmes, G. (1939) *Brain* 62, 1–30
- 7 Fiez, J., Petersen, S., Cheney, M. and Raichle, M. (1992) *Brain* 115, 155–178
- 8 Van Essen, D. C., Anderson, C. H. and Felleman, D. J. (1992) *Science* 255, 419–423
- 9 Stein, J. and Glickstein, M. (1992) *Physiol. Rev.* 72, 967–1017
- 10 Glickstein, M., May, J. and Mercier, B. (1985) *J. Comp. Neurol.* 235, 343–359
- 11 Miall, C., Weir, D., Wolpert, D. and Stein, J. J. *Motor Behav.* (in press)

## 'Involvement in' versus 'Storage of'

The manuscript of Leiner, Leiner and Dow extends some of their previous arguments regarding the involvement of the cerebellum in cognitive functions by proposing that the projections from the cerebellar neodentate nucleus to regions of the nervous system involved in cognitive and linguistic behaviors serve as a specific basis for the cerebellum's role in these processes. In addition to citing experimental data they feel support this view, they also assert that this cerebellar region only minimally contributes to the regulation of motor behavior. Independent of the support for the arguments pertaining to the cerebellum's role in cognitive tasks, the assertion that this function actually occurs in the relative absence of an involvement of the neodentate nucleus in motor execution and coordination is difficult to support. My commentary in this debate presents evidence contrary to this.

Although the structural features and interconnections of the human cerebellum have some unique characteristics, the neodentate nucleus clearly exists in other primates<sup>1</sup>. Consequently, the results from experiments in these animals are pertinent to the issue of the possible role of this cerebellar region in motor behavior. It is very clear that permanent and temporary dentate lesions which include regions of the neodentate nucleus can affect motor behavior<sup>2,3</sup>. Literature other than the paper they cite also supports a role for this nuclear region in human motor behavior (see Ref. 4 for review). In evaluating the literature, it is important to keep in mind the recent contributions of Thach<sup>2</sup>, which indicate that the manifestations of cerebellar dysfunction following discrete lesions within the cerebellar nuclei are very dependent on the type of movement that is tested. Consequently, some of the

**Commentary by  
James R. Bloedel**  
Division of  
Neurobiology, Barrow  
Neurological Institute,  
St Joseph's Hospital  
and Medical Center,  
350 W Thomas Rd,  
Phoenix, AZ 85013,  
USA.



negative findings might be related to the fact that only relatively restricted movements were used to evaluate the deficit. In my view there is not an adequate basis in the literature for dismissing the view that the neodentate nucleus is fundamentally important in regulating features of motor behavior.

Leiner, Leiner and Dow also contend that the basis for reciprocal connections involving the cerebellar nuclei is to provide a basis by which the cerebellum 'can improve the performance of any other part of the brain . . .'. The implications of this statement are not entirely clear. However, if this interpretation were true, would it not be equally feasible for this to provide the circuitry by which extracerebellar sites could 'improve' interactions occurring in the cerebellum?

Interestingly, this article also suggests that the cerebellum performs a rather comparable operation across all the sites to which it projects. We agree with this point and in fact have emphasized a similar view in a recent review<sup>5</sup>, proposing that the cerebellar sagittal zone is the structural unit which conveys this operation to specific extracerebellar sites. Based on this concept, the structural consistency among the zones provides the framework for the similarity of operation across the various regions of the cerebellum, and the specific projections from restricted cerebellar nuclear regions to different extracerebellar locations provide the topographic specificity required for the cerebellum's selective, task-specific action on individual components of the sensorimotor system. Extending this view (see also Ref. 5), the functions ascribable to the cerebellum would be related to the specific functions performed by a spectrum of regions receiving inputs from cerebellar efferent pathways. Unequivocally these functions may include those which are not confined to somatomotor behavior. For example, the classic review by Dow and Moruzzi<sup>6</sup> emphasized the possible role of cerebellar output systems in regulating autonomic behavior. It is now known that there are several substrates for these interactions. Similarly, it is not inconceivable that the cerebellum, through its interactions with appropriate regions of the thalamocortical and limbic systems, could be involved in certain types of cognitive processes, particularly those related to planning, execution or learning of movements. It may be through the interactions of the cerebellum that cognitive activity related to movement planning is integrated with sensory information from a variety of proprioceptive and exteroceptive inputs in formulating 'body scheme'<sup>7</sup>, which is now known to be important in determining the behavior elicited by descending pathways under different sets of sensory conditions.

In my view one of the most appealing features of the article was the consistent emphasis by these authors on the cerebellum's *involvement* in cognitive processes rather than its role in the *storage* of the memory engrams established during motor learning. Our laboratory has never contended that the cerebellum was not *involved* in task acquisition of either motor or nonmotor behaviors. Furthermore, we have never proposed that the cerebellum

is devoid of any plasticity associated with the learning of specific tasks. Rather, we have emphasized those notions related to the issue of motor learning which are directly supported by our data: namely, that the climbing fiber system plays its primary role in cerebellar function by producing short-lasting interactions rather than long-term plastic changes of Purkinje-cell responsiveness to parallel fiber inputs, and that the plasticity required for the acquisition of the classical conditioning of the rabbit nictitating membrane reflex and specific types of volitional, operantly conditioned arm movements does not reside *exclusively* in discrete regions within the cerebellum. Consequently, I welcome the re-emphasis of these authors on the cerebellum's *participation* in the critical processes of task acquisition and motor learning and, yes, even in cognitive processes, particularly those relating to motor planning, motor performance and updating of body scheme. After all, there is a substantial interface between cognition and motor behavior—they cannot be considered as completely separate and distinct functions, but rather as cooperative functions whose interrelationship is a key to several aspects of motor planning and motor execution.

It should also be emphasized that the activation of cerebellar structures on an imaging study such as PET cannot discriminate between activity that is related to the processing of sensory information which results in virtually no changes in behavior and activity that reflects the activation of cerebellar efferent projections that exert functionally relevant actions required for the execution of a specific behavior. The literature on seizures clearly illustrates this point. There are many studies showing the modulation of cerebellar activity during cortical seizures as the result of the activation of cerebellar afferent systems by corticofugal projections. Despite the dramatic nature of this activity, it may not be reflected in behavioral changes relatable to the action of cerebellar efferent systems<sup>8</sup>.

In conclusion, although the article reiterates some interesting issues, a definable role of the cerebellum in purely non-motor cognitive processes will require substantially more experimental support before it can become a generally-accepted notion.

#### Selected references

- 1 Larsell, O. and Jansen, J. (1972) *The Comparative Anatomy and Histology of the Cerebellum: The Human Cerebellum, Cerebellar Connections, and Cerebellar Cortex*, University of Minnesota Press
- 2 Thach, W. T., Goodkin, H. P. and Keating, J. G. (1992) *Annu. Rev. Neurosci.* 15, 403–442
- 3 Flament, D. and Hore, J. (1986) *J. Neurophysiol.* 55, 1221
- 4 Gilman, S., Bloedel, J. R. and Lechtenberg, R. (1981) *Disorders of the Cerebellum*, Davis Co.
- 5 Bloedel, J. R. *Behav. Brain Sci.* (in press)
- 6 Dow, R. S. and Moruzzi, G. (1958) *The Physiology and Pathology of the Cerebellum*, University of Minnesota Press
- 7 Gurfinkel, V. S., Levik, Y. S., Popov, K. E., Smetanin, B. N. and Shlikov, V. Y. (1988) in *Stance and Motion. Facts and Theories* (Gurfinkel, V., Yoffe, M., Massion, J. and Roll, J.-P., eds), pp. 185–189, Plenum Press
- 8 Davis, R. and Bloedel, J. R. (1984) *Cerebellar Stimulation for Spasticity and Seizures*, CRC Press

## The role of the cerebellum in the human brain

Reply by H. C. Leiner, A. L. Leiner, and R. S. Dow

In replying to the commentaries on our article, we start by recapitulating our proposal about the evolution of human language. How this human language capacity, unique in the animal kingdom, was able to evolve in the brain has not yet been adequately explained<sup>1</sup>. Its evolution required that the brain perform rapidly both the motor and cognitive processing that underlie fluent speech. Both such processes can be performed by the models of the cerebellum that we discuss now. On the basis of this modeling, we propose that the evolution of cerebellar capabilities in the human brain could have been a prerequisite for the evolution of human language.

### Motor and non-motor models of the cerebellum

Models of cerebellar function have recently been expanded beyond motor function to include cognitive function. How motor models can be expanded in this way and yet remain firmly grounded in cerebellar anatomy is indicated by some data on the cerebellar dentate nucleus, which were reported by Thach and his colleagues<sup>2</sup>. The dentate nucleus in the monkey seems to contain a map of the animal's body parts, whose movements can be controlled by the cerebellum. In this map, it is the head (rather than the limbs or trunk) that is represented in the ventrolateral part of the dentate nucleus. Because this ventrolateral part evolved in humans into an enormous neodentate structure, it is important to ask what movement in the human head can the neodentate control? The following answer makes it possible to regard cognitive function as an expansion of motor function.

Just as some parts of the cerebellum can target the cerebral motor cortex, which contains representations of the animal's body parts<sup>2</sup>, so the neodentate can target the cerebral prefrontal cortex, which contains symbolic representations of information, or ideas, or concepts. We have shown that the output connections of the dentate nucleus are optimally organized for transmitting symbols to the cerebral cortex (see Ref. 3, particularly p. 122, section 4); and we have proposed that the manipulation of these symbols in the prefrontal cortex constitutes the 'movement' that the neodentate can control. Controlling the traffic of such symbols as they flow through a network is a basic function that computing machines perform in their internal operations. By manipulating and routing these internal symbols effectively, a computing mechanism can carry out a broad range of internal operations, including both the motor and non-motor operations that have been attributed to the human cerebellum; namely, counting, timing, sequencing, predicting and anticipatory planning, error-detecting and correcting, shifting of attention, pattern generation, adaptation and learning. (See Table I in our article.)

Some of the cognitive attributes in this list have been questioned by some investigators of cerebellar function, who find inconsistencies in the published data<sup>4,5</sup>. But such controversy concerns only the data derived from patients whose cerebellum is defective, not the data from normal adults. In patients, the inconsistencies may reflect the differing locations of the cerebellar damage and the differing test protocols. However, in normal adults the data are consistent. Neuroimaging studies indicate that the human cerebellum is an active participant both in motor activities and in some non-motor activities, such as silent counting<sup>6</sup> and cognitive word-processing<sup>7</sup>.

The cerebellum can therefore be modelled as a computational network capable of carrying out some of the motor and non-motor processes that contemporary computing systems are known to perform. Such computational models have been proposed by Drs Ito, Paulin, Courchesne, Gluck, Houk, Moore and others<sup>8-13</sup>. The formulation of these various models makes it possible to investigate their proposed explanations about the role of the cerebellum in the brain.

### Reply to Professor Ito's commentary

Ito's comprehensive model supports a broad view of cerebellar function. His model indicates how the cerebellum can function as a multi-purpose adaptive or learning device, capable of contributing to all kinds of neural control, motor and non-motor. We have tried to carry forward such modeling in our discussion (in the preceding section) of the neural basis of symbol-processing. We suggest that this symbol-processing approach may help to illuminate how the cerebellum can manipulate numerical symbols during silent counting<sup>6</sup>, and verbal symbols during language-processing<sup>7</sup>.

### Reply to Professor Glickstein's commentary

A much narrower view of cerebellar function is adopted by Glickstein, who regards the cerebellum solely as a motor mechanism. In his commentary on our article, he refutes arguments that we did not make and draws conclusions that are unwarranted. For example, he says in his second paragraph that cerebellar size alone is not a sufficient argument to demonstrate cognitive functions. We did not say it was; we considered that the enlarged size of the human dentate nucleus gave rise to new neural connections that have as their targets some expanded prefrontal areas, which evolved concomitantly with the human neodentate and which send back new connections to the neodentate. We have painstakingly traced these newly-evolved connections in the human in our various publications since 1986, and none of these neuroanatomical data has been refuted.

In addition to his anatomical argument, Glickstein cites the clinical data in the writings of Holmes, who made no mention of cognitive deficits in cerebellar patients. As it happens, one of us (R.S.D.) worked with Holmes and knows from personal experience that the techniques available for testing patients today are far more sophisticated than those available fifty years ago<sup>14</sup>. Therefore, it is not surprising that the subtle cognitive deficits now being revealed by modern testing techniques were not found by Holmes 50 years ago.

Clinical data from a more recent patient<sup>15</sup>, a lawyer, are also cited by Glickstein, who draws conclusions about language that are unwarranted. Tests of this patient revealed that, even though he seemed to retain the language skills that he had acquired before his lateral cerebellum was damaged, the lateral damage produced serious impairments. He was tested on word-generation tasks, which he failed to complete successfully and learn normally. In addition to a profound learning deficit, he also was profoundly deficient in detecting and correcting the verbal errors that he made, of which he was often unaware<sup>15</sup>. From these data one cannot conclude, as Glickstein does in his summary, that language abilities are essentially normal after damage to the lateral cerebellum.

Lastly, Glickstein cites at length some data on visual pathways in the monkey, but these neural connections are not relevant to our proposal because the brain of the monkey has neither the differentiated language structures nor the language function that we discussed in our article. Our article discussed cognitive processes that are associated with human language, not cognition in general. Therefore, it was necessary for us to show that the newly-evolved parts of the human cerebellum can participate in such processes through neural projections to and from language areas of the cerebral cortex (e.g. Broca's area), which we showed.

To summarize our reply: the anatomical and clinical arguments in Glickstein's commentary do not refute our article. More important, his commentary does not consider the relevant neuroimaging

data that undermine a solely motor view of cerebellar functions.

#### Reply to Dr Bloedel's commentary

Midway between Ito's broad viewpoint and Glickstein's narrow one is the viewpoint expressed by Bloedel<sup>16</sup>. Although he, like Glickstein, is primarily interested in the motor functions of the cerebellum, he is open-minded about our proposal that the human cerebellum also contributes to certain cognitive and language functions. He concludes that more experimental work is needed to define the role of the cerebellum in purely non-motor processes, and we agree with this.

Concerning Bloedel's statement that the neodentate clearly exists in other primates, we emphasize that a difference exists between the human neodentate and the dentate nucleus of subanthropoid primates. While precursors of the human neodentate can be found in lower primates, only in anthropoids and humans have these structures evolved into a distinct region of the dentate nucleus, a region which enlarged enormously in humans.

#### Selected references

- 1 Deacon, T. W. (1990) *Am. Zool.* 30, 629-706
- 2 Thach, W. T., Goodkin, H. P. and Keating, J. G. (1992) *Annu. Rev. Neurosci.* 15, 403-442
- 3 Leiner, H. C., Leiner, A. L. and Dow, R. S. (1991) *Behav. Brain Res.* 44, 113-128
- 4 Daum, I. et al. (1993) *Behav. Neurosci.* 107, 411-419
- 5 Glickstein, M. (1993) *Trends Neurosci.* 16, 450-451
- 6 Ryding, E., Decety, J., Sjöholm, H., Stenberg, G. and Ingvar, D. H. (1993) *Cognitive Brain Res.* 1, 94-99
- 7 Raichle, M. E. et al. *Cerebral Cortex* (in press)
- 8 Ito, M. (1993) *Trends Neurosci.* 16, 448-450
- 9 Paulin, M. G. (1993) *Human Move. Sci.* 12, 5-16
- 10 Courchesne, E., Akshoomoff, N. A., Townsend, J. and Saitoh, O. *Electroenceph. Clin. Neurophysiol.* (in press)
- 11 Gluck, M. A. and Granger, R. (1993) *Annu. Rev. Neurosci.* 16, 667-706
- 12 Houk, J. C., Kiefer, J. and Barto, A. G. (1993) *Trends Neurosci.* 16, 27-33
- 13 Moore, J. W., Desmond, J. E. and Berthier, N. E. (1989) *Biol. Cybern.* 62, 17-28
- 14 Dow, R. S. (1988) *J. Clin. Neurophysiol.* 5, 307-323
- 15 Fiez, J. A., Petersen, S. E., Cheney, M. K. and Raichle, M. E. (1992) *Brain* 115, 155-178
- 16 Bloedel, J. R. (1993) *Trends Neurosci.* 16, 451-452

### Writing for *TINS*

Most of the articles published in *Trends in Neurosciences* are specially invited by the editor. However, unsolicited articles will also be considered for publication. If you wish to write for *TINS*, please contact the editor, or a member of the Editorial Advisory Board first, with an outline of your intended article.

### Letters to the Editor

Letters to the editor of *Trends in Neurosciences* concerning recently published articles in the journal are welcomed. Please mark clearly whether they are intended for publication.

Please address letters to:  
Editor  
*Trends in Neurosciences*  
Elsevier Trends Journals  
68 Hills Road  
Cambridge, UK CB2 1LA.